

CENTURION UNIVERSITY OF  
TECHNOLOGY AND MANAGEMENT



Centurion  
UNIVERSITY

Shaping Lives...  
Empowering Communities...

CENTER FOR

# SMART INFRASTRUCTURE



SMART CITIES  
SMART ENERGY  
SMART BUILDINGS  
INTERNET OF THINGS



[www.cutm.ac.in](http://www.cutm.ac.in)

VERSION: 1/2023

# Centre for Smart Infrastructure Research Center

Centurion University of Technology &  
Management, Odisha, India



**Centurion**  
**UNIVERSITY**

*Shaping Lives...*  
*Empowering Communities...*

**CEO**

**Dr. Ashish Ranjan Dash**

**RC Coordinator**

**Dr. Rajendra Kumar Khadanga**

**Mentor**

**Prof. Jagannath Padhi**

*Energy is essential for development, and sustainable energy is essential for sustainable development —*

—Tim Wirth

## Team Members: Centre for Smart Infrastructure



**Dr. Ashish Ranjan Dash**  
**Dean, School of Engineering**  
**CEO**



**Dr. Rajendra Kumar Khadanga**  
**Asso. Professor, EEE**  
**RC Coordinator**



**Mrs. Debashree D. Behera**  
**Asst. Professor, Mechanical**  
**RC Member**



**Mr. Nimay Chandra Giri**  
**Asst. Professor, ECE**  
**RC Member**



**Mr. Smruti Ranjan Nayak**  
**Asst. Professor, ECE**  
**RC Member**



**Mr. Surya Narayan Sahu**  
**Asst. Professor, EEE**  
**RC Member**



**Mr. Deepak Kumar Sahu**  
**Asst. Professor, Civil**  
**RC Member**



**Dr. Saine Sikta Dash**  
**Asst. Professor, Civil**  
**RC Member**



**Mr. Rama Prasanna Dalai**  
**Asst. Professor, EEE**  
**RC Member**



**Dr. Rajib Kumar Majhi**  
**Asst. Professor, Civil**  
**RC Member**



**Mr. Rajesh Kumar Mishra**  
**Asst. Professor, ECE**  
**RC Member**



**Mrs. N. Jeevaratnam**  
**Asst. Professor, ECE**  
**RC Member**



**Mr. Abinash Rath**  
**Asst. Professor, EEE**  
**RC Member**



**Mr. B Bikram Narayan**  
**Asst. Professor, Civil**  
**RC Member**



**Dr. Prangya Parimita Pradhan**  
**Asst. Professor, EEE**  
**RC Member**



**Dr. Shiv Shankar Das**  
**Asst. Professor, SoM**  
**RC Member**

## Message from CEO, Smart Infrastructure

Dear colleagues, partners, and stakeholders,

At Smart Infrastructure, our mission is to revolutionize infrastructure systems by embracing cutting-edge technologies, innovative practices, and collaboration. We aim to create intelligent, efficient, and resilient cities, transportation networks, energy systems, and buildings.



Our key pillars of focus are knowledge generation, collaboration, innovation, career enhancement, R&D support, and publication. We strive to be a knowledge hub, conducting ground-breaking research and developing innovative solutions in Engineering and Technology. By collaborating with leading scientists, universities, organizations, and industry leaders, we accelerate innovation and leverage diverse perspectives. We foster an ecosystem that promotes innovative and entrepreneurial thinking, empowering our researchers, students, and staff to explore unconventional ideas and turn them into reality. Our goal is to push the boundaries of what is possible and unlock breakthrough solutions.

We extend our impact beyond academia by enhancing career opportunities for students through industry-institute interaction and value-added projects. By bridging the gap between academia and industry, we equip students with the necessary skills and experiences for success in the rapidly evolving field of smart infrastructure.

Supporting the R&D activities of our industry partners is crucial. Through consultancy services, we provide expertise, guidance, and tailored solutions for industrial projects. We understand the importance of translating research outcomes into practical applications and strive to drive real-world impact. Publication and knowledge dissemination are integral to our mission. We encourage RC members to publish their findings in reputable peer-reviewed journals, contributing to the global knowledge base. We also explore patenting opportunities to protect innovative solutions and foster commercialization.

Together, we have the power to transform infrastructure systems and build a sustainable future. We invite everyone to join us on this journey of collaboration, innovation, and inspiration. Let's work together towards a world where smart infrastructure becomes the foundation of progress and prosperity.

We express gratitude for the unwavering support and commitment received thus far. With confidence, we believe that by working together, we will achieve remarkable milestones and create a lasting impact.

Sincerely,

Dr. Ashish Ranjan Dash,  
CEO, Smart Infrastructure

# Contents

<b>1</b>	<b>Introduction</b>	<b>1</b>
1.1	Aim and objective of the RC .....	1
1.2	Focus Area .....	1
1.3	Software Tools .....	2
1.4	Student Involvement .....	2
1.4.1	Expected Outcomes .....	2
1.4.2	Activities being carried out .....	3
<b>2</b>	<b>Research and Projects</b>	<b>3</b>
2.1	Projects.....	3
2.1.1	Polyhouse Automation.....	3
2.1.2	Image Processing Based Plant Disease Detection for polyhouse Application.....	10
2.1.3	Design of RFID based attendance system .....	11
2.1.4	Development of Microgrid inside the Campus.....	11
2.1.5	Economical Design and analysis of Windmill inside campus ...	12
2.1.6	Installation of Solar tree inside campus.....	13
2.1.7	Installation of solar powerplant inside campus .....	15
2.1.8	Repair and maintenance of 32kwp Solar powerplant .....	16
2.1.9	EV Charging Station .....	18
2.1.10	Development of solar parabolic through collector .....	19
<b>3</b>	<b>Publications, Patents, Internships and Workshops</b>	<b>20</b>
3.1	Journals .....	20
3.2	Patents .....	26
3.3	Conference and Book Chapters .....	27
3.4	CEO Retreat at Sai Resorts Vishakapatnam .....	31
3.5	Faculty Awards .....	31
3.6	Future Plans .....	32

# 1. Introduction

The Centre for Smart Infrastructure was established in the year 2020 with an aim to develop low-cost, indigenous technologies through Research & Development (R& D).

## 1.1 Aim and objective of the RC

The main objectives of the Research Centre are:

- To be a renowned knowledge generator and repository for innovative technological and inclusive solutions in the areas of Engineering and Technology.
- To develop cooperation at national and international levels with universities, leading scientists, and Industries.
- To promote the introduction of innovative and entrepreneurial thinking.
- Enhancing the career opportunities for students through industry- institute interaction, and value-added projects in cutting- edge of technology.
- Supporting the Research & Development activities as a consultancy for industrial projects.
- Publication of research results in National and international peer- reviewed journals and filing patents.

## 1.2 Focus Area

- ***Smart Energy Systems:*** This focus area involves exploring innovative technologies and systems for energy generation, distribution, and consumption in infrastructure.
- ***Intelligent Transportation Systems:*** This focus area involves studying and developing intelligent transportation solutions to improve mobility, safety, and sustainability.
- ***Sustainable Buildings and Infrastructure:*** This focus area involves developing sustainable and energy-efficient building designs, materials, and construction practices.
- ***Data Analytics and Artificial Intelligence:*** This focus area involves leveraging data analytics and artificial intelligence techniques to optimize the performance and operation of infrastructure systems.
- ***Internet of Things (IoT) and Connectivity:*** This focus area involves exploring the application of IoT technologies and connectivity solutions in infrastructure systems.



- ***Urban Planning and Smart Cities:*** This focus area involves studying the integration of smart infrastructure technologies in urban planning and the development of smart cities.

### **1.3 Software Tools**

We have access to the State of Art simulation tools such as MATLAB, 3D-experiences [BIM], Auto-CAD, REVIT, STAAD-Pro, Student Involvement

### **1.4 Student Involvement**

The Centre encourages and involves Undergraduate & Postgraduate students and Research scholars besides faculty members to carry out the re- search activities.

### **1.5 Expected Outcomes**

1. *Knowledge Generation and Repository:* The expected outcome is the generation of new knowledge through research activities and the establishment of a repository of innovative solutions that can be accessed by researchers, professionals, and industry practitioners.
2. *National and International Cooperation:* The expected outcomes include knowledge exchange, joint research projects, and shared resources that can contribute to advancements in engineering and technology.
3. *Promotion of Innovative and Entrepreneurial Thinking:* Development of a mindset that embraces creativity, problem-solving, and the ability to translate research outcomes into practical applications and entrepreneurial ventures.
4. *Enhanced Career Opportunities for Students:* Internships, industry collaborations, and value-added projects that can equip students with relevant skills and experiences sought by employers.
5. *Support for Industrial Projects:* By offering consultancy services, the center can provide expertise and solutions to industry-specific challenges, leading to the development of innovative and practical outcomes for industrial applications.
6. *Research Publication and Patents:* To contribute to the academic and scientific community's knowledge base by sharing research findings. Additionally, filing patents can protect and commercialize innovative solutions, potentially leading to technological advancements and economic benefits.

## 1.6 Activities being carried out

- We organize professional development workshops and FDP/SDP on problems identified by the research work conducted at the Center for the training of faculty academic staff and students to share research findings with them.
- Organization of Industry talks to educate the members about simulation tools.
- Product development
- Offering Domain/Skill, Certification Courses, and Internships.

## 2. Research and Projects

### 2.1 Projects

#### 2.1.1 Polyhouse Automation

Polyhouse farming is a special kind of arrangement in which the crop field is completely or partially covered by transparent polyethene sheets. The nutrients are dissolved in water and supplied to plants through drip irrigation. The following parameters such as temperature, light intensity, humidity, and moisture of the soil should be adjusted in such a way that different plants can grow perfectly. Different sensors such as temperature sensor, light sensor, humidity sensor, and soil moisture sensor have been used for collecting data and send to the data base. Users can login to monitor and actuate globally. Monitoring data can be downloaded in CSV format.





**Fig. 1.** Inauguration of Phenotyping Unit

### ***Need of Polyhouse Automation***

- Polyhouse is a type of greenhouse where specialized polythene sheet is used as a covering material under which the crops can be grown in partially or fully controlled climatic conditions.
- Modern-day polyhouses are built on G.I. steel frame and are covered with plastic, which is fixed on the frame with aluminum grippers. So, the farmers become confused and follow rough, inaccurate thumb rules.
- The white plastic film used for covering is of high quality; 200 microns thickness, with 3 years guarantee against degradation due to UV and weather. Mostly drip irrigation system is installed inside a polyhouse for watering purpose.
- Polyhouse protects the crops from wind, rain, radiation, precipitation and other climatic factors.
- It creates microclimate surrounding the crops that help in maximum growth regarding production and quality.
- Polyhouse crops can give you maximum profit in a minimum area under cultivation.
- With a maximum level of automation, the number of manual activities, dependency on labor and overall labor cost is reduced.

## Product/Technology/IP Strategy

The proposed automation system is based on the internet of things (IOT), it is cloud of interconnected physical devices which are used to communicate with each other with help of internet.

- Several polyhouses can be monitored in single web or app
- Monitoring and Actuation can be done globally
- Each parameter like temperature, humidity and moisture sensor can be controlled for individual polyhouse



**Fig. 2. Control Panel**



**Fig. 3. IOT Controller box**

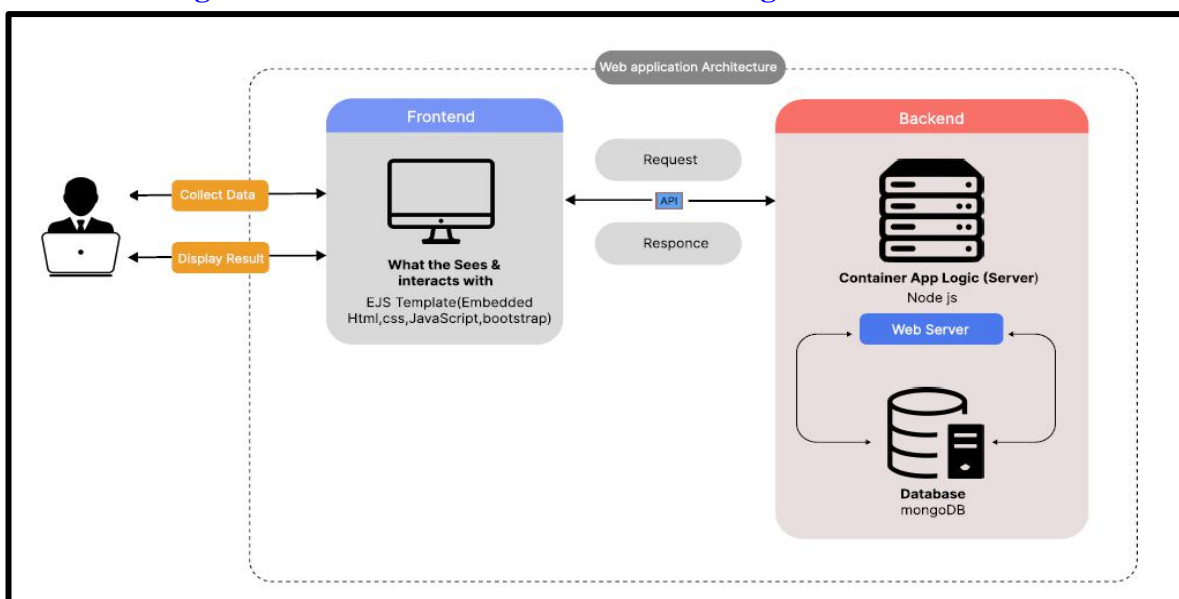

**Fig. 4. Web Application Architecture**

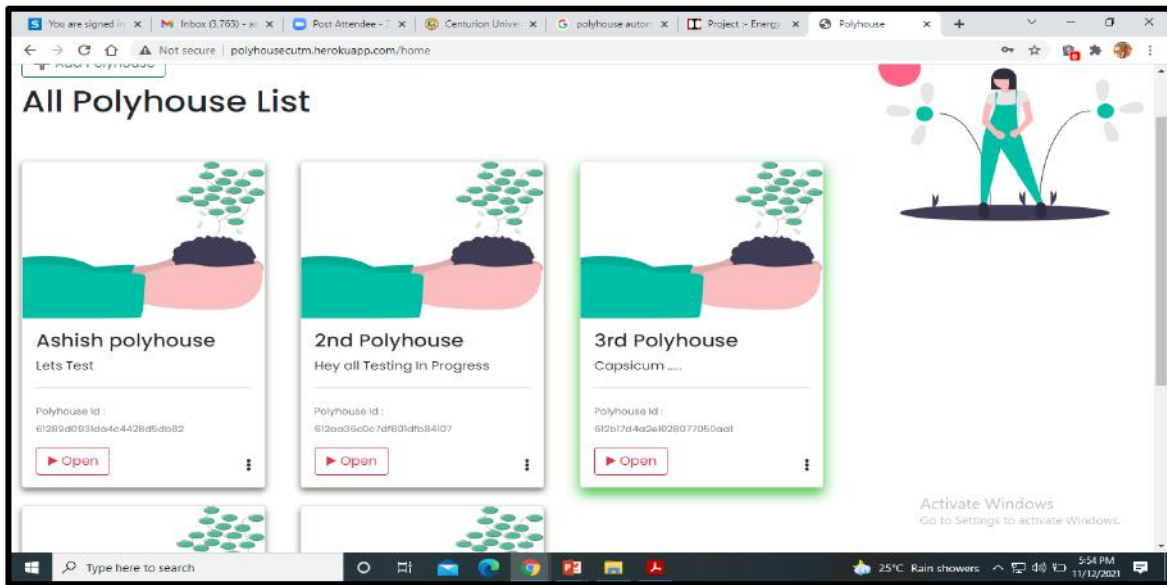

Fig. 5. Web and database management

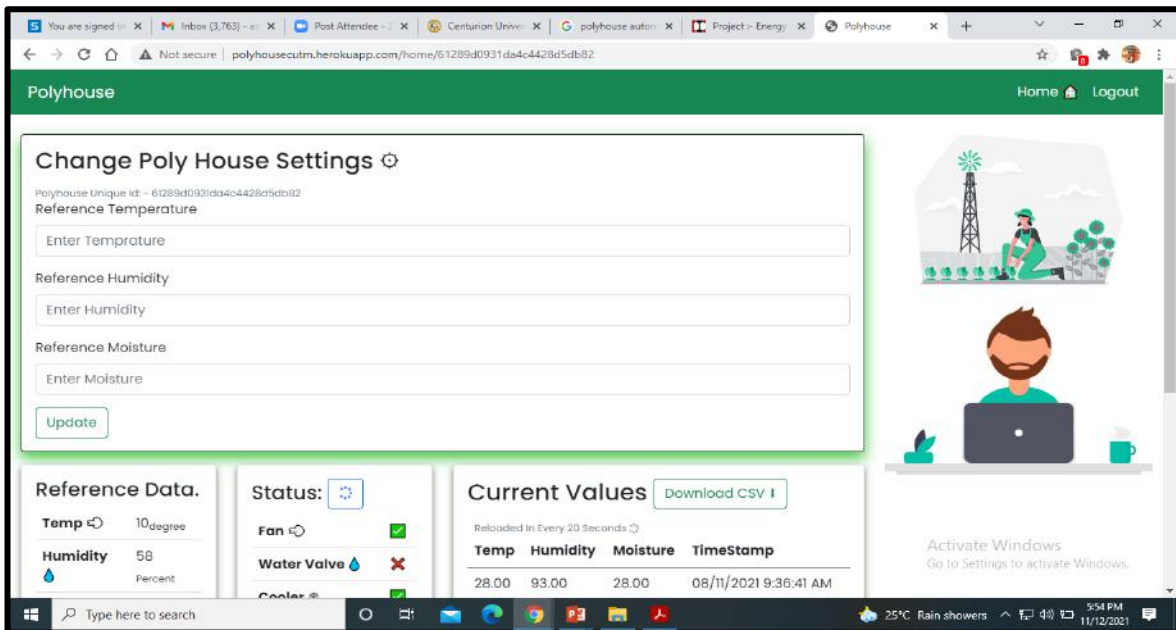

Fig. 6. Web and database management



**Fig. 7.** Automated polycarbonate-based polyhouse (Inside)



**Fig. 8.** Automated polycarbonate-based polyhouse (Outside)



**Fig. 9.** Polyhouse at Ranadevi, Paralakhemundi campus



**Fig. 10.** Forced ventilated polyhouse

*Automated Polyhouse by our proposed Technology*

**Table 1.** List of different automated polyhouse projects

Name of the polyhouse	Size	Type	Controlling option
Ranadevi 1	12.5m 8m	forced ventilation	Temp, humidity, soil moisture
Ranadevi 2	12.5m 8m	OPEN ventilation	humidity, soil moisture
Ranadevi 3	12.5m 8m	OPEN ventilation	humidity, soil moisture
Vizianagaram	24m 24m	forced ventilation	Temp, humidity, soil moisture

*Specifications of Actuators*

**Table 2.** Detail specification of the actuators used in automated polyhouse

Name	Size	Rating
Exhaust Fan	5.6m×8m Blade: 5.6 ft × 3.8 ft	3 phase, 1 hp
Fan Pad	20 ft × 60 ft	Colling cellulose
Solenoid valve	40 mm	220V AC
Dripper	16 mm	2 LPH
Fogger	24 mm	Four Way
Pressure motor	-	Single phase, 0.5 hp
Submersible motor	-	Single phase, 0.5 hp

### ***Automation of open Agricultural fields***

- A smart IOT-based control mechanism is developed which remotely manages water and nutrient system with the help of IoT/Cloud system. It manages the supply and distribution of water and nutrient to small and marginalized farmers from a shared water and nutrient resource and manages the operations. The dynamic water demand-supply management is based on real time data from meters communicating with the Cloud Network. Water and nutrient can be supplied automatically in a controlled fashion to the fields. This not only conserves water and reduces cost of water, but also keeps the water level in good conditions, and improves water ecosystem. It also conserves the soil fertility using precision nutrient.
- Intelligent control algorithms control the pumps for irrigation. The solution is applicable to all types of irrigation systems, whether conventional grid-connected or solar off-grid, existing or new, AC or DC, submersible or surface. This creates a viable option to share irrigation pump in a financially sustainable model, saves O&M costs, and increases the life of pump. The solution can be used for stand-alone solar-water-pumping systems, pumping system powered with microgrids, or traditional pumping system powered by the grid electricity. The focus is on shared resources, water conservation, and sustainable business model.

### ***Monitoring Parameters***

In this project on speed breeding, we will monitor several key parameters to ensure the success and efficacy of our breeding program. These parameters may include the

- Light spectrum intensity, and duration,
- Temperature and humidity levels of the growth chamber.
- The nutrient levels
- pH balance,
- water quality
- Percentage of CO<sub>2</sub> of the growing medium to ensure optimal plant growth and development.



## 2.1.2. Image Processing Based Plant Disease Detection for polyhouse Application

Green plants are very much important to the human environment; they form the basis for the sustainability and long-term health of environmental systems. In this project, we have proposed a system using Nodemcu (ESP8266)/raspberry pi to detect healthy and unhealthy plants & alerts the farmer by sending email.

Technologies	Software
<ul style="list-style-type: none"> <li>→ Open CV</li> <li>→ Python</li> <li>→ Webserver</li> <li>→ KERAS 2.2.4</li> </ul>	<ul style="list-style-type: none"> <li>→ Matlab Software</li> <li>→ Jupyter Notebook</li> </ul>
Controller	Algorithm
<ul style="list-style-type: none"> <li>→ NodeMcu(ESP8266)</li> <li>→ Rasberry pi</li> </ul>	<ul style="list-style-type: none"> <li>→ Capture the RGB format image</li> <li>→ Convert RGB shading regards to the predefined space in that structure</li> <li>→ Apply image segmentation</li> <li>→ Clustering</li> </ul>

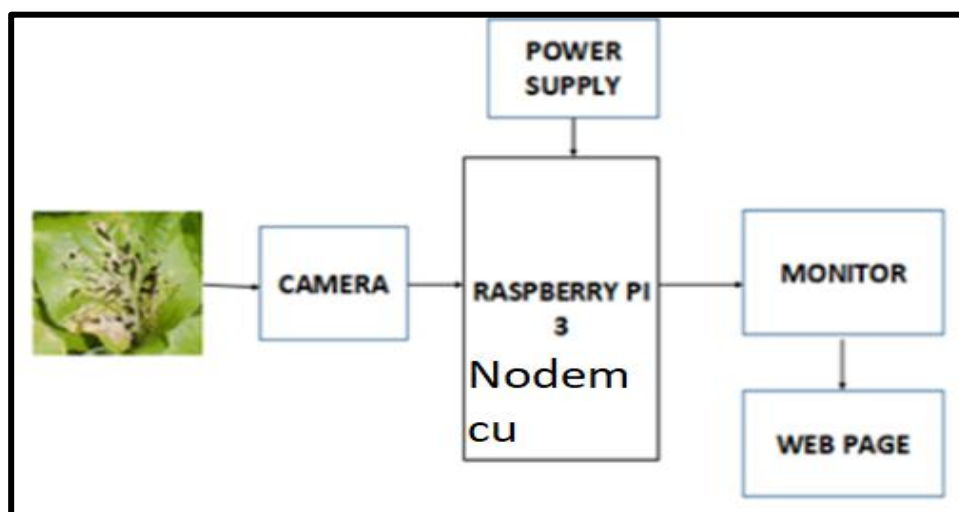

**Fig. 11.** Schematic presentation of Plant Disease Detection through image processing

### 2.1.3. Design of RFID based attendance system

RFID stands for radio-frequency identification, and it uses electromagnetic fields to quickly identify and track tags that are attached to objects. These tags store critical information on your employees so you can know exactly when they enter and exit the building. The outcome of the product is Students able learn about RFID technology, Students able learn controller programming, Student able learn web page designing and data base management, finally able design a prototype model.



**Fig. 12.** Prototype of RFID

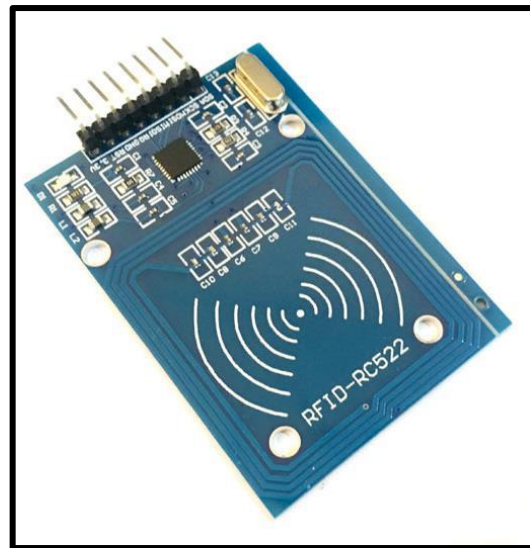
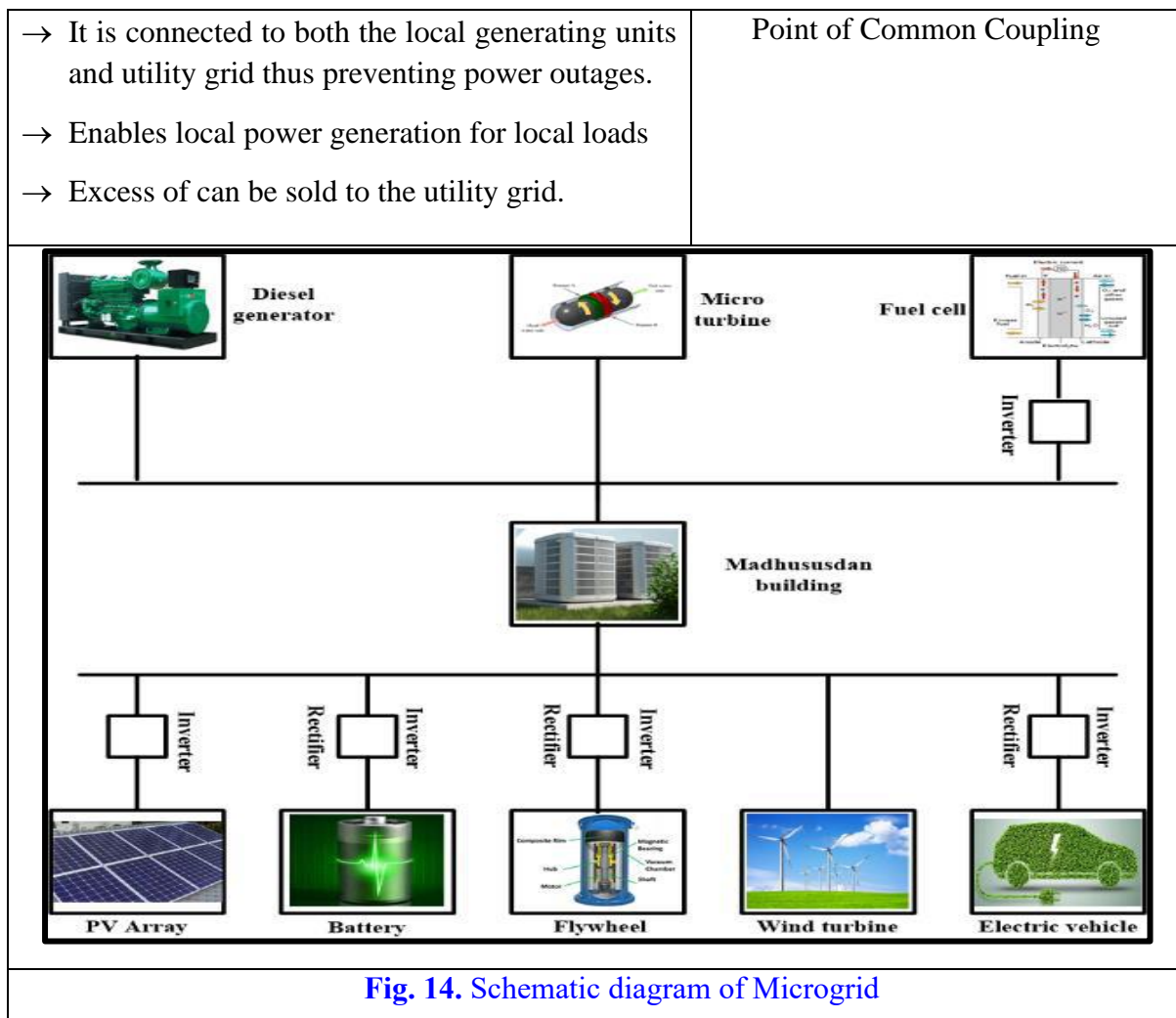

**Fig. 13.** Controller board of RFID

### 2.1.4. Development of Microgrid inside the campus

A microgrid is a group of interconnected loads and distributed energy resources within clearly defined electrical boundaries that acts as a single controllable entity with respect to the grid.

About	Main Components of Microgrid
<ul style="list-style-type: none"> <li>→ The concept of microgrid is considered as a collection of loads and micro-sources which functions as a single controllable system that provides both power and heat to its local area.</li> <li>→ Comprises of various small power generating sources that makes it highly flexible and efficient.</li> </ul>	<ul style="list-style-type: none"> <li>→ Distributed Generation</li> <li>→ Loads</li> <li>→ Energy storage system</li> <li>→ Static disconnect switch</li> <li>→ Controller</li> <li>→ Mode switching device</li> </ul>



### 2.1.5. Economical Design and analysis of windmill inside Campus

The majority of wind turbines consist of three blades mounted to a tower made from tubular steel. There are fewer common varieties with two blades or with concrete or steel lattice towers. At 100 feet or more above the ground, the tower allows the turbine to take advantage of faster wind speeds found at higher altitudes. The objectives of the plant are to design and develop a efficient solar energy harvesting system for our society and to develop a Portable & adjustable structure for optimum energy production.

- For the installation of the wind power plant inside the CUTM, BBSR campus, the following literature studies have been carried out: -
- The wind data (Speed, Direction) for the required location (CUTM, BBSR) for the last 5 years has been collected from IMD Pune.



**Fig. 15.** Installed Microgrid inside campus

### 2.1.6. Installation of Solar tree inside campus

A solar tree is a structure incorporating solar energy technology on a single pillar, like a tree trunk.

<b>About</b>
<ul style="list-style-type: none"> <li>→ Solar trees are intended to bring visibility to solar technology and to enhance the landscape and architecture they complement, usually in a commercial or public context.</li> <li>→ Likewise, the arrangement of solar panels in a solar tree must ensure maximum efficiency in harnessing the solar energy.</li> <li>→ In botanical context phyllotaxy is the arrangement of leaves over a stem.</li> <li>→ One panel should not be covered by the shade of the upper panels.</li> </ul>
<b>Objective</b>
<ul style="list-style-type: none"> <li>→ A solar tree is a decorative means of producing solar energy and also electricity. It uses multiple no of solar panels which forms the shape of a tree. The panels are arranged in a tree fashion in a tall tower/pole.</li> </ul>

→ This project work aims on solving this problem by providing supplement power through a SOLAR TREE with a battery storage system which can provide a steady-state power at different slots of time as per requirement

### Proposed Design

Nine numbers of 75 Wp Polycrystalline Solar panels will be used to provide 675 Wp power at output.

**Table 3. Components of Polycrystalline Solar panel**

#	Items	Specification	Qty	Make
1	Poly Solar Panels	75 W 12 V system	9	NOVA
2	PWM Controller	12 V 40 A	1	
3	Or MPPT Micro Controller	110-240 V, 4 A	1	Schneider
4	Solar Battery	12 V 40 Ah	2	Luminous
5	Connecting Wire	1-2 mm		
6	DCDB	30-40 A	1 or 2	
7	Mechanical Structure	GI		

**Table 4. Load Estimation**

Load (DC)	Watts	Qty	No. of hour uses	Consumption
<b>Appliances</b>				
LED Light	9	5	4	180
Fan	12	6	6	432
Multi Mobile Charging Point	40	1		40
<b>Or Irrigation</b>				
Solar Water Pump	0.5 or 1 HP	1		
LED Light	5	4	4	80
Fan	12	2	6	144
Multi Mobile Charging Point	40	1		40

**Table 5. Cost Estimation**

#	Items	Qty	Approx. Cost (Rs.)
1	GI Mechanical Structure with Leaf	1	25,000
2	Civil Foundation	1	5,000
3	Battery (12 V 40 Ah)	2	12,000
4	Solar Pump Set (12 V 0.5 HP)	1	20,000
5	Multi Mobile Charging Point (12 V)	1	2,000
6	Charge Controller (PWM)	1	5,000
7	Wire/DCDB/Cashing		3,000
8	Miscellaneous		3,000
	<b>Total (Rs.)</b>		<b>75,000</b>



**Fig. 16.** On-going installation of solar tree



**Fig. 17.** Installed solar tree



**Fig. 18.** Working of the installed solar tree inside campus

### 2.1.7. Installation of Solar power plant inside campus

#### About

Solar energy is radiant light and heat from the sun that is harnessed using a range of technologies such as solar power to generate electricity. Now a days solar energy is mostly used in our domestic or industrial purposes. The solar panel will be used to create the solar energy by the help of photovoltaic cell. It consumes the sun light and convert it into the electricity. A solar power plant is a facility that converts solar radiation, made up of light, heat, and ultraviolet radiation, into electricity suitable to be supplied to homes and industries.

### Objective

- To design and develop a efficient solar energy harvesting system for our society.
- To develop a Portable & adjustable structure for optimum energy production.

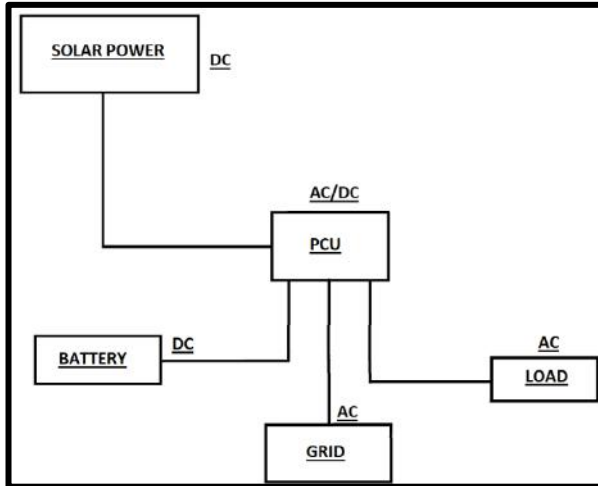

**Fig. 19.** Schematic diagram of solar power plant



**Fig. 20.** Installation of solar power plant

## 2.1.8. Repair and Maintenance of 32kwp Solar Power Plant

### About

In CUTM Bhubaneswar Campus, a 32.5 kWp capacity grid interactive solar PV system was installed in 2018. It was running smoothly with full capacity. In view of cyclone Fani on May, 2019 we had dismantled the entire system for safe keeping. It is now reinstalled with our own manpower and synchronized to grid with full capacity operation, which was inaugurated by Hon'ble VC Prof. (Dr.) Supriya Pattanayak on 14/12/2021.

### Objective

- To design and develop an efficient solar energy harvesting system for our society.
- To develop a Portable & adjustable structure for optimum energy production.

### System Specification

**Table 6.** System Specification

Specification	Unit- 1	Unit- 2
Max Load that can be connected	11 kW	11 kW
Max units of energy (kWh) usage per day	37.3Units	37.3Units
System Voltage	240 V	240 V
Solar Module with mounting structure	16.25 kWp	16.25 kWp

Solar battery with battery rack	400 Ah, 240 V	400 Ah, 240 V
Solar Power Conditioning Unit – Single Phase	20 kVA, 240 V	20 kVA, 240 V
Cables & Consumables	1 Set	1 Set

**Table 7. Total System Capacity: 32.5 kWp**

No. of Shops connected	10nos.
Average solar irradiation in ODISHA state	1156.39W/sq.m
Average Energy over the year (considering 5.5 sunshine hours)	5.5 Sunshine Hours
Carbon dioxide emissions mitigated is	905 tonnes.
This installation will be equivalent to planting	1448 Teak trees over the life time. (Data from IISc)



**Fig. 21. Installation of solar PV system**



**Fig. 22. Controller of solar PV system**

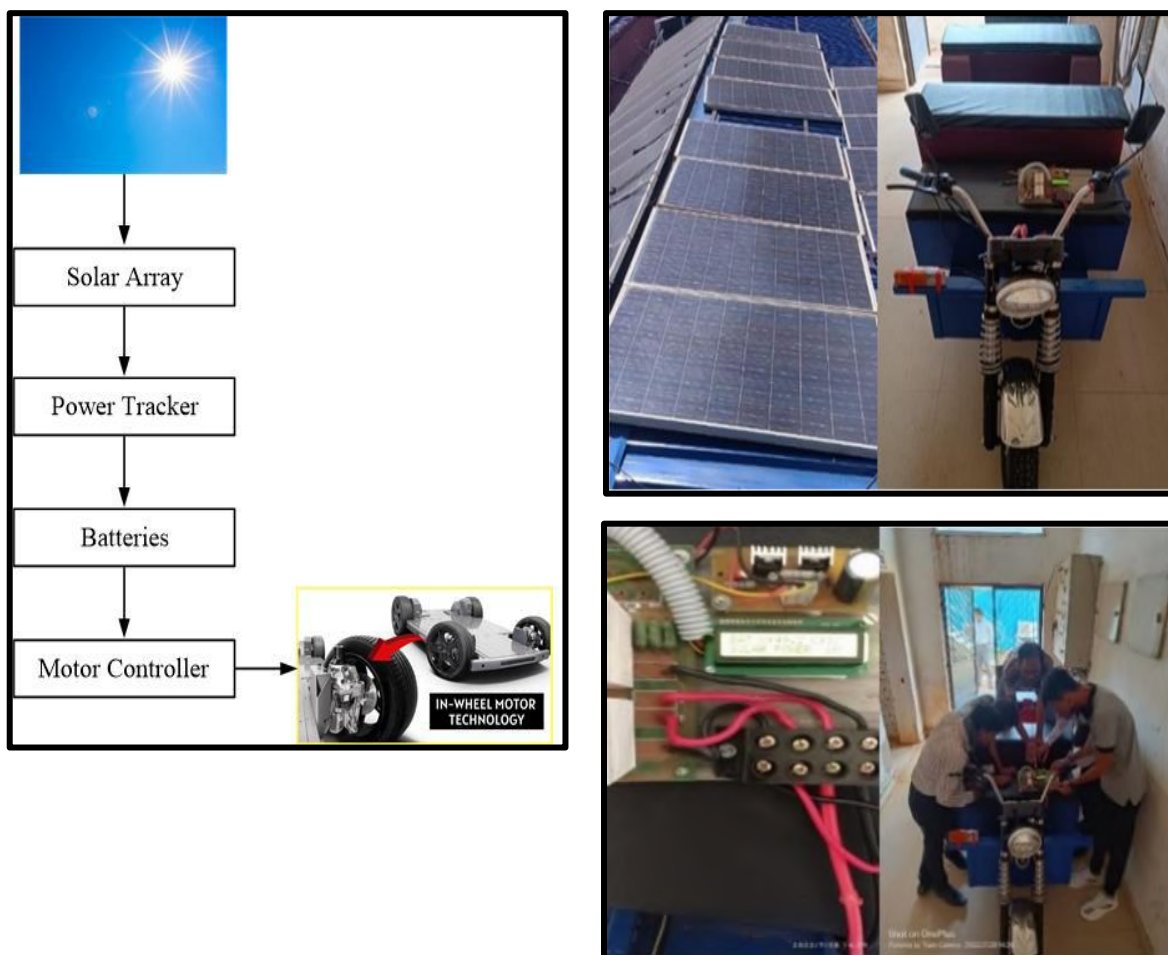

**Fig. 23. Inauguration of 32.5 kWp capacity grid interactive solar PV system by Hon'ble Vice-Chancellor, CUTM, Odisha**



### 2.1.9. EV Charging Station

Air pollution creates a key role in climate change and its impact on our health and wellbeing. The transport sector contributes a major part to air pollution (40-70%) in Indian cities. To decarbonize the transport sector, the electric vehicles (EVs) deployment with clean technology sources is a suitable option in the country. In this invention, a 2 KWp of solar rooftop photovoltaic (SRTPV) system has been used to charge four numbers of lead acid batteries (12V each) through an EV charging station (EVCS). In peak hours, the 2 KWp SRTPV produces 8-10 units/day. Around 4 hours is enough in peak time to charge the batteries of the EV. It is economically cheaper than those with grid configuration/conventional charging.



**Fig. 24.** Solar rooftop photovoltaic (SRTPV) system

### 2.1.10. Development of solar parabolic trough collector

<b>About</b>
A parabolic-trough collector (PTC) is a linear-focus solar collector, basically composed of a parabolic-trough-shaped concentrator that reflects direct solar radiation onto a receiver or absorber tube located in the focal line of the parabola
<b>Objective</b>
→ To develop the prototype for water heating and cooking purposes. → To model the prototype by using Catia software and temperature analysis by using ANSYS software
<b>Learning Outcomes</b>
→ The student will be able to understand the concept and design of parabolic trough collector → It will generate maximum temperature up to 200-300 <sup>0</sup> C

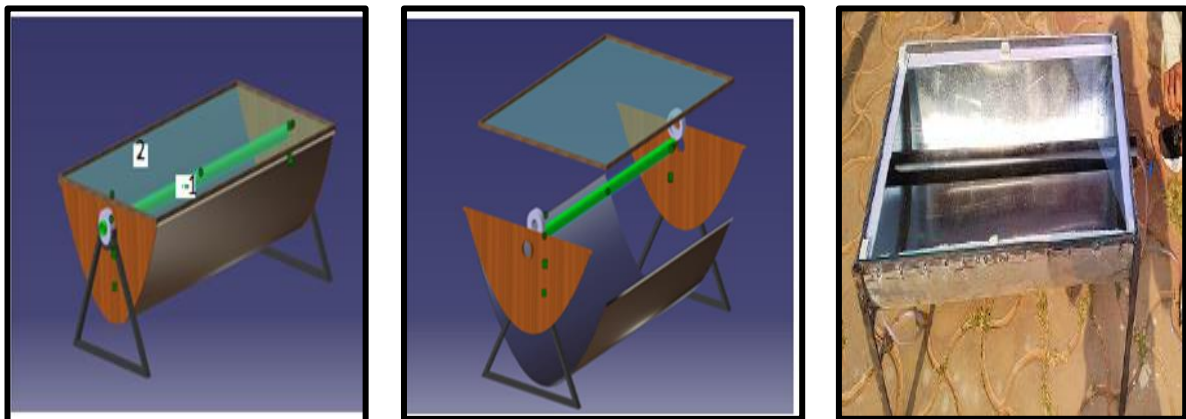

Fig. 28. Prototype of a solar parabolic trough collector

### 3 Publications, Patents, Internships and Workshops

#### 3.1 Journals

<b>Dr. Ashish Ranjan Dash</b>	
1	Lenka, R. K., Panda, A. K., Dash, A. R., Senapati, L., & Tiwary, N. (2022). A unified control of grid-interactive off-board EV battery charger with improved power quality. <i>IEEE Transactions on Transportation Electrification</i> .
2	Lenka, R. K., Panda, A. K., Dash, A. R., Venkataramana, N. N., & Tiwary, N. (2021, January). Reactive Power Compensation using Vehicle-to-Grid enabled Bidirectional Off-Board EV Battery Charger. In <i>2021 1st International Conference on Power Electronics and Energy (ICPEE)</i> (pp. 1-6). IEEE.
3	Damala, R. B., Patnaik, R. K., & Dash, A. R. (2022). A simple decision tree-based disturbance monitoring system for VSC-based HVDC transmission link integrating a DFIG wind farm. <i>Protection and Control of Modern Power Systems</i> , 7(1), 25.
4	Behera, R. R., Dash, A. R., & Panda, A. K. (2021, August). Cascaded Transformer coupled Multilevel inverter-based Shunt Active Power Filter. In <i>2021 Asian Conference on Innovation in Technology (ASIANCON)</i> (pp. 1-6). IEEE.
5	Behera, R. R., Dash, A. R., & Panda, A. K. (2022). A novel cascaded transformer coupled multilevel inverter with reduced number of switches for high power applications. <i>World Journal of Engineering</i> , (ahead-of-print).
6	Behera, R. R., Dash, A. R., Patel, R., & Panda, A. K. (2023, January). Implementation of a novel Hebbian least mean square techniques to a Cascaded MLI based SAPF. In <i>2023 International Conference on Power Electronics and Energy (ICPEE)</i> (pp. 1-6). IEEE.
7	Damala, R. B., Dash, A. R., & Patnaik, R. K. (2022). Change detection filter technique-based fault analysis of HVDC transmission line. <i>World Journal of Engineering</i> , (ahead-of-print).
8	Dash, A. R., Patel, R., Mangaraj, M., & Panda, A. K. (2021). Implementation of an Efficient SVPWM Technique to a Cascaded Multilevel Inverter-Based SAF. In <i>Advances in Smart Grid and Renewable Energy: Select Proceedings of ETAEERE 2020</i> (pp. 437-446). Springer Singapore.
<b>Dr. Rajendra Kumar Khadanga</b>	
9	Khadanga, R. K., Das, D., Kumar, A., & Panda, S. (2023). Sine augmented scaled arithmetic optimization algorithm for frequency regulation of a virtual inertia control based microgrid. <i>ISA transactions</i> .
10	Nayak, S. R., Khadanga, R. K., Panda, S., Sahu, P. R., Padhy, S., & Ustun, T. S. (2023). Participation of Renewable Energy Sources in the Frequency Regulation Issues of a Five-Area Hybrid Power System Utilizing a Sine Cosine-Adopted African Vulture Optimization Algorithm. <i>Energies</i> , 16(2), 926.
11	Khadanga, R. K., Nayak, S. R., Panda, S., Das, D., Prusty, B. R., & Sahu, P. R. (2022). A Novel Optimal Robust Design Method for Frequency Regulation of Three-Area Hybrid Power System Utilizing Honey Badger Algorithm. <i>International Transactions on Electrical Energy Systems</i> , 2022.
12	Sahu, P. R., Lenka, R. K., Khadanga, R. K., Hota, P. K., Panda, S., & Ustun, T. S. (2022). Power System Stability Improvement of FACTS Controller and PSS Design: A Time-Delay Approach. <i>Sustainability</i> , 14(21), 14649.

13	Das, D., Khadanga, R. K., & Rout, D. K. (2023). A matching game framework for users clustering and resource allocation with wireless power transfer in a CR-NOMA network. <i>International Journal of Communication Systems</i> , 36(2), e5376.
14	Khadanga, R. K., Kumar, A., & Panda, S. (2022). A modified grey wolf optimization with cuckoo search algorithm for load frequency controller design of hybrid power system. <i>Applied Soft Computing</i> , 124, 109011.
15	Khadanga, R. K., Das, D., Kumar, A., & Panda, S. (2022). An improved parasitism predation algorithm for frequency regulation of a virtual inertia control based AC microgrid. <i>Energy Sources, Part A: Recovery, Utilization, and Environmental Effects</i> , 44(1), 1660-1677.
16	Khadanga, R. K., & Panda, S. (2022). A modified local input signal for SSSC-based damping controller design. <i>Electric Power Components and Systems</i> , 49(11-12), 978-989.
17	Khadanga, R. K., Kumar, A., & Panda, S. (2021). A novel sine augmented scaled sine cosine algorithm for frequency control issues of a hybrid distributed two-area power system. <i>Neural Computing and Applications</i> , 1-14.
18	Khadanga, R. K., Kumar, A., & Panda, S. (2021). Application of interval type-2 fuzzy PID controller for frequency regulation of ac islanded microgrid using modified equilibrium optimization algorithm. <i>Arabian Journal for Science and Engineering</i> , 46(10), 9831-9847.
19	Kumar Khadanga, R., Kumar, A., & Panda, S. (2021). Frequency control in hybrid distributed power systems via type-2 fuzzy PID controller. <i>IET Renewable Power Generation</i> , 15(8), 1706-1723.
20	Kumar, A., Khadanga, R. K., & Panda, S. (2022). Reinforced modified equilibrium optimization technique-based MS-PID frequency regulator for a hybrid power system with renewable energy sources. <i>Soft Computing</i> , 1-19.
21	Choudhury, S., Acharya, S. K., Khadanga, R. K., Mohanty, S., Arshad, J., Ur Rehman, A., ... & Choi, J. G. (2021). Harmonic Profile Enhancement of Grid Connected Fuel Cell through Cascaded H-Bridge Multi-Level Inverter and Improved Squirrel Search Optimization Technique. <i>Energies</i> , 14(23), 7947.
22	Khadanga, R. K., Nayak, S. R., Panda, S., Das, D., Prusty, B. R., & Sahu, P. R. (2022). A Novel Optimal Robust Design Method for Frequency Regulation of Three-Area Hybrid Power System Utilizing Honey Badger Algorithm. <i>International Transactions on Electrical Energy Systems</i> , 2022.
<b>Mrs. Debashree D. Behera</b>	
23	Behera, D. D., Mohanty, A. M., & Mohanty, R. C. Recent advances in solar drying technologies: A Comprehensive review. <i>Journal of Energy Systems</i> , 6(4), 503-519.
24	Debashree Debadatta Behera, Ayush kumar Sahu, Subrat Nayak, Soumya Sonali Kar, Gagan Patra, Sushmita Rani Pradhan (2022). Performance Evaluation of a Solar Parabolic trough Concentrator, <i>Ambient Science</i> , 9 (1).
25	Behera, D. D., Mohanty, R. C., & Mohanty, A. M. (2022). Performance evaluation of indirect type forced convection solar mango dryer: A sustainable way of food preservation. <i>Thermal Science</i> , (00), 154-154.
26	Behera, D. D., Das, S. S., Mishra, S. P., Mohanty, R. C., Mohanty, A. M., & Nayak, B. B. (2022). Simulation of solar operated grass cutting machine using PVSYST software. <i>Materials Today: Proceedings</i> , 62, 3044-3050.

27	Behera, D. D. (2020). Development of a Solar Operated Blower for Forging Operation: An Initiative for Sustainable Livelihood of Rural Area, <i>International Journal of Engineering and Advanced Technology</i> , 9 (3), 3281-3284.
28	Behera, D. D., Mohanty, R. C., & Mohanty, A. M. (2020). Performance evaluation of hybrid solar dryer for drying food products. <i>International Journal of Advanced Science and Technology</i> , 29(3), 7788-800.
	<b>Mr. Nimay Chandra Giri</b>
29	D. Yadav, N. Singh, V.S. Bhadoria, Nimay Chandra Giri, and M. Cherukuri (2023). A Novel Metaheuristic Jellyfish Optimization Algorithm for Parameter Extraction of Solar Module. <i>International Transactions on Electrical Energy Systems</i> .
30	DP Mishra, BS Panda, NS Mallik, S Kar, NC Giri (2023). Demand side management in a microgrid to reduce the peak consumption cost. <i>International Journal of Power Electronics and Drive Systems</i> , 14 (2), 819-826
31	Giri, N. C., Shah, K. K., Ray, S. S., Vennila, H., Das, S., Sandhya, Y. B., & Pradhan, I. (2022). Photovoltaic pumping system vs livelihoods and sustainability. <i>Ambient Sci</i> , 9(1), 27-30.
32	Choudhary, R., Naresh, R. K., Chandra, M. S., Chandra, N., Giri, K. L., & Tiwari, H. (2021). Conservation tillage and integrated nutrient management impact on soil organic carbon fractions, labile soil organic matter pools and microbial community under rice-wheat cropping system: A review.
33	Sima, S., Giri, N. C., Nayak, S., Routray, S., Tamboli, D., & Gajjar, R. (2022). ReHoMation: low cost, RF based remotely home automation without microcontroller. <i>Indian J. Nat. Sci</i> , 13, 42235-42241.
34	Giri, N. C., & Mohanty, R. C. (2022). TRADITIONAL VERSUS UNDERNEATH FARMING OF TURMERIC AND GINGER IN ODISHA, INDIA. <i>International Journal of Agricultural &amp; Statistical Sciences</i> , 18(1).
35	Giri, N. C., & Mohanty, R. C. (2022). Design of agrivoltaic system to optimize land use for clean energy-food production: a socio-economic and environmental assessment. <i>Clean Technologies and Environmental Policy</i> , 24(8), 2595-2606.
36	Giri, N. C., & Mohanty, R. C. (2022). Agrivoltaic system: Experimental analysis for enhancing land productivity and revenue of farmers. <i>Energy for Sustainable Development</i> , 70, 54-61.
37	Vennila, H., Giri, N. C., Nallapaneni, M. K., Sinha, P., Bajaj, M., Abou Houran, M., & Kamel, S. (2022). Static and dynamic environmental economic dispatch using tournament selection based ant lion optimization algorithm. <i>Frontiers in Energy Research</i> , 10, 972069.
38	Hariharan, K. B., Lenin, K., Dhanabalan, S., Palanisamy, R., Giri, N. C., Bajaj, M., ... & Kamel, S. (2022). Experimentation on AISI T42 tool steel at very low temperature. <i>Journal of Materials Research and Technology</i> , 21, 1682-1704.
39	Ramshanker, A., Chakraborty, S., Elangovan, D., Kotb, H., Aboras, K. M., Giri, N. C., & Agyekum, E. B. (2022). CO2 Emission Analysis for Different Types of Electric Vehicles When Charged from Floating Solar Photovoltaic Systems. <i>Applied Sciences</i> , 12(24), 12552.
40	Tripathy, S., Sahoo, M. M., Giri, N. C., Mishra, S. P., & Nayak, S. R. (2021). Sustainable Emergency Light for Scarcely Electrified Area of India. <i>Current Journal of Applied Science and Technology</i> , 40(11), 74-82.

41	Pani, B. B., Giri, N. C., Nayak, S. R., & Mishra, S. P. (2021). Fault Detection and Troubleshooting in a PV Grid-Tied Inverter. <i>Indian Journal of Science and Technology</i> , 14(22), 1829-1838.
42	Giri, N. C., Mohanty, R. C., & Mishra, S. P. (2021). Smart shift from photovoltaic to agrivoltaic system for land-use footprint. <i>Ambient Science</i> , 8(2).
43	Giri, N. C., Mishra, S. P., Choudhury, S., Mishra, B. P., Vennila, H., & Roja, M. (2021). Pragmatic Shift from Conventional to Solar Off-Grid Access to Electricity in Isolated Places. <i>Current Journal of Applied Science and Technology</i> , 40(23), 34-40.
44	Giri, N. C., & Mohanty, R. C. (2020). Accelerating India's energy sector to sustainable sources, potentials and prospects. <i>Indian Journal of Natural Sciences</i> , 10(58), 18066-18076.
45	Giri, N. C., & Mohanty, R. C. (2020). Performance evaluation of one MW on-grid SPV power generation plant in odisha, India. <i>Indian J. Nat. Sci.</i> , 10(58), 18084-18091.
46	Chandra shekhar Dash, S.N. Padhi & Nimay Chandra Giri (2020). ASIC implementation of CMOS Vedic Multiplier, <i>Journal of Xidian University</i> , 14(5): 5098-6003.
47	Nimay Chandra Giri, Debraj Rana (2020). Live Video Processing using Computer System Toolbox, <i>Indian Journal of Natural Sciences</i> , 10(60): 20947-20953, 2020.
48	Giri, N. C., Rana, D., Mish, S. P., & Pani, B. B. (2020). Efficacy of Solar Powered Water Pumps for Rural Farmers in Odisha; India. <i>PalArch's Journal of Archaeology of Egypt/Egyptology</i> , 17(9), 2215-2224.
49	Giri, N. C., Mishra, S. P., & Mohanty, R. C. (2020). Performance Parameters, Optimization, and Recommendation in Large Scale On-Grid SPV Power Plant, Odisha, India. <i>International Journal of Modern Agriculture</i> , 9(4), 159-167.
	<b>Mr. Deepak Kumar Sahu</b>
50	Deepak Kumar Sahu ; Pradip Sarkar ; Robin Davis ; and Sujith Mangalathu, published a SCIE, SCOPUS (IF:5.318) on High-Dimensional Model Approach for Stochastic Response of Multispan Box Girder Bridges, / Volume 27 Issue 9 - September 2022.
	<b>Mr. Rama Prasanna Dalai</b>
51	Priyanka Hemant Kale, Chandra Mohan M, S.John Justin Thangara, Rama Prasanna Dalai, Chidananda.H published a WoS journal paper on Develop a model for assessing the most efficient disease diagnosis using image processing, <i>Bulletin of Environment, Pharmacology and Life Sciences</i> , April , 2022
52	Rama Prasanna Dalai, Smita Jana, Sudip Gupta, Jharna Majumdar published WoS journal paper on A Comparative Study of LQR and PID Controller for the Speed Control of a DC Motor, <i>Indian Journal of Natural Sciences</i> , June 2022.
53	S Jana, RP Dalai, S Gupta, J Majumdar published a WoS paper on A Comprehensive Study of a PID controller for Speed Control of DC Motor, in <i>IJONS</i> , 2021
54	S Tripathy, RP Dalai published a SCOPUS paper on Design and Analysis of Voltage Regulator for a Microgrid for Voltage Regulation and Protection, <i>Design Engineering in 2021</i> .
55	RP Dalai, SN Sahu published a WoS paper on Relay Coordination Analysis of an Educational Institute using ETAP Software, <i>Shodh Sanchar Bulletin</i> , UGC 2020

56	RP Dalai, SN Sahu, S Sidharth published a WoS paper on Impact of the Pan India Lights OFF on Indian Electricity Grid on 5th April 2020, <i>Indian Journal of Natural Sciences</i> , 2020.
57	RP Dalai, S Sidharth published a WoS paper on CAN Communication in Automotive Industry, <i>Indian Journal of Natural Sciences</i> , 2020.
58	RP Dalai, S Sabyasachi published a WoS paper on Future of Drone Technology in India, <i>Indian Journal of Natural Sciences</i> in 2020.
<b>Dr. Rajib Kumar Majhi</b>	
59	RK Majhi, AN Nayak & RB Swain (2021). "Structural performance of RC beams containing high-volume ground granulated blast furnace slag and recycled coarse aggregate with lime", <i>Construction and Building Materials</i> , 307, 124907. (IF: 7.639).
60	RK Majhi, SK Patel & AN Nayak (2021). "Sustainable structural lightweight concrete utilizing high-volume fly ash cenosphere", <i>Advances in Concrete Construction</i> , 12 (3), 257-270. (IF: 3.214).
61	Bibhu P. Lenka, Rajib K. Majhi, Subhralina Singh & Amar N. Nayak (2021). "Eco-friendly and cost-effective concrete utilizing high-volume blast furnace slag and demolition waste with lime", <i>European Journal of Environmental and Civil Engineering</i> , 25, 1-23. (IF: 2.816).
62	Majhi, R. K., Padhy, A., & Nayak, A. N. (2021). Performance of structural lightweight concrete produced by utilizing high volume of fly ash cenosphere and sintered fly ash aggregate with silica fume. <i>Cleaner Engineering and Technology</i> , 3, 100121.
63	RK Majhi, Laxmidhar Behera (2021), Mechanical Properties of Concrete Containing Densified Micro Silica as Partial Replacement of Cement, <i>Indian Journal of Natural Sciences</i>
64	RK Majhi, DK Das, K. Kumar, B. Singh, BP Reddy (2022). A Review on Effect of Terrazymeon the Geotechnical Behaviour of Fly Ash-Stabilized Soil, <i>Indian Journal of Natural Sciences</i>
65	RK Majhi, SK Panda, SS Subhankar and AK Patra (2022). The Impact of COVID-19 on the Construction Project Management in Odisha, <i>Indian Journal of Natural Sciences</i> .
<b>Mrs. N. Jeevaratnam</b>	
66	Pooja Singh, N. Jeebaratnam, Harish G Ugraiyah, Mrs.Galiveeti Poornima, Mr Ajay P published a SCOPUS indexed paper on "ADAPTIVE FACIAL RECOGNITION AND SPOOFING DETECTION FOR MANAGEMENT DECISION MAKING SYSTEMS:A VISUALLY IMPAIRED PEOPLE PERSPECTIVE",volume 8 Issue 4,14874-14884, Scopus, journal name:NVEO(Natural Volatiles & Essential Oil,e-ISSN:2148-9637.
<b>Combine Authorship</b>	
67	Debashree Debadatta Behera, Shiv Shankar Das & Nimay Chandra Giri (2020). Performance testing of hybrid type solar dryer by using multiple regression technique, <i>Indian Journal of Natural Sciences</i> , 10(60): 19886-19897.
68	Shiv Shankar Das, Nimay Chandra Giri, Debashree Debadatta Behera (2020). Diffusion of Solar Lights in South Odisha, <i>Indian Journal of Natural Sciences</i> , 10(60): 20589-20596.
69	Nimay Chandra Giri, Shiv Shankar Das, Debashree Debadatta Behera (2020). Sustainable Energy Irrigation Model for Enhancing Livelihood in South Odisha, <i>Indian Journal of Natural Sciences</i> , 10(60): 20947-20953.

70	Nimay Chandra Giri, Shiv Shankar Das, Debashree Debadatta Behera (2020). Sustainable Energy Irrigation Model for Enhancing Livelihood in South Odisha, <i>Indian Journal of Natural Sciences</i> , 10(60): 20947-20953.
71	Mishra, S. P., Giri, N. C., Behera, D. D., & Nayak, S. R. (2020). Solar trees: Shift from grey to green sky for future fuel pumps under clean/green energy: India. <i>Int J of Env Clim Change</i> , 10(11), 68-86.
72	Nayak, B. B., Kumar, N., Singh, A., Sahu, S., Das, S. S., Behera, D. D., & Sahu, R. K. (2022). Genetic programming approach to predict the performance characteristics of WEDM taper cutting process. <i>Materials Today: Proceedings</i> , 62, 4504-4508.
73	Behera, D. D., Mohanty, R. C., Mohanty, A. M., Das, S. S., & Nayak, B. B. (2022, October). Performance evaluation of the Absorbing Plate of a Hybrid Solar Dryer for Potato Drying. In <i>IOP Conference Series: Earth and Environmental Science</i> (Vol. 1084, No. 1, p. 012011). IOP Publishing.
74	Das, S. S., Nayak, B. B., Behera, D. D., Sahu, R. K., Sahu, S., & Giri, S. R. (2022, October). Sustainable Energy Business Model and Strategies for Marketing of Clean Energy Products in Rural Areas of India. In <i>IOP Conference Series: Earth and Environmental Science</i> (Vol. 1084, No. 1, p. 012001). IOP Publishing.
75	Das, S. S., Behera, D. D., & Nayak, B. B. (2022). Use of clean energy for sustainable livelihood in rural areas: A case from South Odisha. <i>Materials Today: Proceedings</i> , 60, 765-772.
76	Pradhan, A., Bhatta, R. K., Das, S. S., Gupta, A. K., & Behera, D. D. (2021). Preparation of Biodiesel from Castor Oil and Performance Evaluation in VCR Engine. <i>Journal of Scientific Research and Reports</i> , 27(6), 84-94.
77	Das, S. S., Behera, S. R., Behera, D. D., & Patnaik, S. (2021). Consumer's Perception in Adoption of Clean Energy Products in Areas of South Odisha. <i>Current Journal of Applied Science and Technology</i> , 40(8), 7-12.
78	Das, S. S., Behera, D. D., and Mishra, S. P (2021). Use of Clean Energy in On-Farm Lively- hood Security". <i>Asian Journal of Agricultural Extension, Economics &amp; Sociology</i> , 39 (5), 16-28.
79	Behera, D. D., Mishra, S. P., Das, S. S., Mohanty. A.M., Mohanty. R.C., Nayak, B.B. (2021). Performance Analysis of PVT Based Hybrid Type Solar Dryer for Drying Food Products, <i>Ambient Science</i> , 8 (2), 1-6
80	Das, S. S., & Behera, D. D. (2020). Sustainable Energy Service Model and Solar Technology Intervention for Drying Fish: A Case Study from SELCO and VIEWS from South Odisha. <i>PalArch's Journal of Archaeology of Egypt/Egyptology</i> , 17(7), 7360-7370.
81	Das, S. S., Behera, D. D., Mishra, S. P., & Pradhan, G. (2020). Clean energy access and productive use by bottom of pyramid clients in Ethnic & Tribal Areas of Odisha: An Appraisal. <i>Current Journal of Applied Science and Technology</i> , 39(36), 38-50.
82	Behera, D. D., S.S. Das. published a UGC Care journal on Adoption of Clean Energy Products in Regions of South Odisha, (2020). 7, 28, Shodh Sarita
83	Behera, D. D., S.S. Das., Mohanty. A.M., Mohanty. R.C. and P. K. Das (2020). Design and Analysis of Solar Agricultural Water Pumping System for Irrigation Purpose. <i>International Journal of Modern Agriculture</i> , 9 (4), 314 – 324.
84	Behera, D. D., Das, S. S., Mohanty, A. M., Mohanty, R. C., & Mohanty, S. (2020). Design and Analysis of Absorbing plate of Hybrid Type Solar Dryer for drying Ginger and Tomato. <i>PalArch's Journal of Archaeology of Egypt/Egyptology</i> , 17(9), 2119-2129.



85	Behera, D. D., Das.S.S and Giri. N published a WoS indexed journal on Performance Testing of Hybrid Type Solar Dryer by Using Multiple Regression Technique”, Indian Journal of Natural Sciences, ISSN No: 0976-0997 (online), Vol.10, Issue 60, June 2020
86	Behera, D. D., Das.S.S Mohanty. A.M., Mohanty. R.C, published a WoS indexed journal on Modelling and Simulation of Solar Tree for Domestic Lightning Purpose, Indian Journal of Natural Sciences, ISSN No: 0976-0997 (online), Vol.10, Issue 60, 2020.
87	Behera, D. D., Das.S.S Mohanty. A.M., Mohanty. R.C published a WoS indexed journal on Experimental study of Solar Dish Type of Solar Concentrator, Indian Journal of Natural Sciences, ISSN No: 0976-0997 (online), Vol.10, Issue 60, 2020
88	Das, S.S and Behera, D. D, published a WoS indexed journal on Clean Energy Products and Distribution, Revenue Col- lection Model”, Indian Journal of Natural Sciences, ISSN No: 0976-0997 (online), Vol.10, Issue 60, June 2020, pp. 24912-24918.

### 3.2 Patents

1. Active Control Applied to Wind Power for Attenuating Torque Harmonics - Filled Application, Number: 202131050399 – Published.
2. A Qualification and labeling Procedure for Inverters for PV systems - Filled Application Number: 202131050804 - Published.
3. Nimay Chandra Giri, and R.C. Mohanty, published a patent on Dynamic solar PV mounting structure, 374952-001, 2023, IN Design.
4. Nimay Chandra Giri, Suraj Kumar, Debani Prasad Mishra, Namrata Sengar, published a patent on "Sustainable onion storage container," 374953-001, 2023. IN Design
5. D.P. Mishra, A.K. Sahoo, R.C. Mohanty, and Nimay Chandra Giri, published a patent on Portable Solar Vegetables Dryer, 376914-001, March 2023. IN Design Grant
6. S. Das, S. Chakravarty, S. Mitra, Nimay Chandra Giri, published a patent on IoT based Camera for Healthcare Management, 376944-001, March 2023. IN Design Grant
7. P. Mishra, T. Mohapatra, S.S. Mishra, Nimay Chandra Giri, published a patent on IoT based agriculture robot for pesticide spraying, 376903-001, March 2023. IN Design Grant.
8. S. Das, T.K. Behera, C. Ray, S. Bakshi, Nimay Chandra Giri, published a patent on "An AI and ML based robotics for remote Agricultural operations and monitoring," 202331025612, April 2023., IN Utility
9. S. Pahadsingh, U. A. Dash, T. Kar, S. Mohapatra, L. Khatua, W. V. Barreto, M. Panda, S. K. Routray, Nimay Chandra Giri, published a patent on "Wearable textile antenna for telemedicine application," 381143-001, 2023. IN Design.
- 10.P. Chatterjee, A Kumar, S Dutta, S Das, T Majumder, S Biswas, Devegowda SR, P.

Mishra, Nimay Chandra Giri, published a patent on "Solar Biomass Integrated Crop Dryer", 380508-001, 2023. IN Design.

11. Nimay Chandra Giri, and R.C. Mohanty, published a patent on Portable Photovoltaic Mounting Assembly for Agrivoltaics, Indian Patent, 202231026515 A, 2022.
12. Nimay Chandra Giri, M Bajaj, N Sengar, S Behera, K Paul, P Mishra, SK Routray, S Mehta, RC Panda, published a patent on "A system for a programmable, timed, wireless, energy-harvesting sensor node utilizing long-range radio access," 20 2022 105 972.1, December 2022. Germany Grant Utility.
13. Nimay Chandra Giri, B. P. Mishra, published a patent on "Solar Sugarcane Juicer with Customized Cooling and Additive Dosage," 201931041144 A, June 2020, IN Utility.
14. Ms. Debashree Debadatta Behera published a patent on SOLAR OPTICAL DESALINATION UNIT, Designed Indian patent granted, patent no: 368071-001.
15. Ms. Debashree Debadatta Behera published a patent on POWDER MANUFACTURING UNIT, Designed Indian patent granted, patent no: 377791-001.
16. Ms. Debashree Debadatta Behera published a patent on Innovation Australian Patent as granted titled "Solar Assisted IOT based Automatic Vertical Medicinal Plant cultivation of critically endangered plant *nardostachys jatamansi*", patent no. 2021103371, 2022.
17. Bhusan Jivan Vispute, M. Ravikiran, Rama Prasanna Dalai, Sangu Navya, Ravaleedhar Reddy Murthy, Pratikshya Gupta and Malliguntha Kiran Kumar Published a Indian Patent on Identify a Distant eight planet solar system using Artificial Intelligence, 202221060893, December 2022.
18. Mrs. N. Jeevaratnam published a patent on "SYSTEM AND METHOD FOR LEARNING ALPHABETIC AND MATHEMATICAL EXPRESSIONS USING A DIGITAL ASSISTANT ", Application Number:20224105509,07-10-2022.
19. Mrs. N. Jeevaratnam published a patent on "AN IMAGE PROCESSING SYSTEM WITH CONVENTIONAL NEURAL NETWORK MODELS METHOD THEREOF", APPLICATION NUMBER:202141047288,18-10-2021.

### **3.3 Conference and Book Chapters**

- 1 R. K. Khadanga, S. Padhy, P.R. Sahu & S. Panda, "Frequency Regulation of a Distributed Power System via Modified Whale Optimization Algorithm", Innovations in Power and Advanced Computing Technologies (IEEE, i-PACT-2021), doi: 10.1109/i-PACT52855.2021.9696834, VIT, Vellore.
- 2 S. Padhy, P.R. Sahu, R.K. Khadanga, B.R. Prusty & S. Panda, "MPA-Tuned Fractional Order PID Controller for Frequency Control of Interconnected Smart Grid Power System", Innovations in Power and Advanced Computing Technologies (IEEE, i-PACT-2021), doi: 10.1109/i-PACT52855.2021.9696651, VIT, Vellore.
- 3 Sima Das, Ajay Kumar Balmiki and Nimay Chandra Giri, published a book chapter on

Artificial Intelligence Enables Agile Software Development Life Cycle, ISBN: 9781119896838, John Wiley & Sons, Inc.

- 4** Nimay Chandra Giri, Bibhu Prasad Ganthia, Selva Suman Ray, published a book on Maintenance schedule of Electrical Substation Equipments, 9789391101848, Educreation Publishing, October 2021.
- 5** Shiv Sankar Das, Debashree Behera, Nimay Chandra Giri, published a book on Clean Energy Applications in Modern World, 9781638069560, Notion Press, February 2021.
- 6** Nimay Chandra Giri, Smruti Ranjan Nayak, Siba Prasad Mishra and Debipada Mishra, published a book chapter on Solar Photovoltaic System, 9789390541935, AkiNik Publications, New Delhi, January 2021.
- 7** Nimay Chandra Giri, Smruti Ranjan Nayak, Siba Prasad Mishra and Surya Narayan Sahu, published a book chapter on Solar PV based Energy Conversion System, 9798587652200, Amazon's, December 2020.
- 8** Ms. Debashree Debadatta Behera published a Book Name: Clean Energy and Rural Development, Book chapters Name: Clean Energy in India: An Overview, ISBN:9798887720401, Notion Press, 2022, <https://amzn.eu/d/3IbPJpL>
- 9** Ms. Debashree Debadatta Behera published a Book Name: Clean Energy and Rural Development, Book chapters Name: Clean Energy And Diffusion of Clean Energy Products in Rural Areas, ISBN:9798887720401, Notion Press, 2022, <https://amzn.eu/d/3IbPJpL>
- 10** Ms. Debashree Debadatta Behera published a Book Name: Clean Energy and Rural Development, Book chapters Name: Entrepreneurial Eco-system, ISBN:9798887720401, Notion Press, 2022, <https://amzn.eu/d/3IbPJpL>
- 11** Ms. Debashree Debadatta Behera published a Book Name: Clean Energy and Rural Development, Book chapters Name : Role of Education in Enhancing QOI of Rural People, ISBN:9798887720401, Notion Press, 2022, <https://amzn.eu/d/3IbPJpL>
- 12** Ms. Debashree Debadatta Behera published a Book Name: Clean Energy and Rural Development, Book chapters Name : Education and Eco- consumption, ISBN:9798887720401, Notion Press
- 13** Ms. Debashree Debadatta Behera published a Book Name: Clean Energy and Rural Development, Book chapters Name: Role of Training and Development for Rural People, ISBN:9798887720401, Notion Press,<https://amzn.eu/d/3IbPJpL>
- 14** Ms. Debashree Debadatta Behera published a Book Name: Clean Energy and Rural Development, Book chapters Name: Case study, ISBN:9798887720401, Notion Press, <https://amzn.eu/d/3IbPJpL>
- 15** Ms. Debashree Debadatta Behera published a Book titled, “Clean Energy Applications in Modern World”, in Notion press bearing ISBN No: 9781638069560 in Feb 2021
- 16** Ms. Debashree Debadatta Behera published a book titled, “Clean Energy Products: A

Path for Attaining Livelihood Security”, in Notion press bearing ISBN No: 9781636691602 in Nov 2020.

- 17** Ms. Debashree Debadatta Behera published a book chapter titled, “Development of a Solar Energy Operated Fish Dehydrator for the Livelihood Security of Fisherwomen of South Odisha” in the book titled “Emerging Trends in Management & Information Technology” bearing ISBN No: 978-81-947590-5-8.
- 18** Mrs. N. Jeevaratnam "Soil Quality: An Agricultural Production Challenge" is accepted for publication in edited book titled "Advanced in agriculture and allied technology" , publisher: Akinik publication,ISBN:978-93-5570-428-3 in Akinik Publications,21-08-2022
- 19** Mrs. N. Jeevaratnam published a book "DIGITAL DATA COMMUNICATION", in Infinite Research, ISBN:978-81-963070-3-5
- 20** Y. Bhanu Sandhya, K. Srinivas Rao, P. Srinath Rajesh, Grkd Satya Prasad, and Nimay Chandra Giri, A Method for Validating Energy Balance and Comfort in Zero-Energy Buildings using Building Energy Simulation Software, ICEEMR 2022, 23rd-24th June 2022.
- 21** Y. Bhanu Sandhya, K. Srinivas Rao, P. Srinath Rajesh, Nimay Chandra Giri, Sima Das and Vikas Singh Bhadoria, Statistical Assessment of Sustainable Energy for the Lowest Feasible Levelized Cost of Electricity, IEEE ICACITE 2022, July 2022.
- 22** Y. Bhanu Sandhya, K. Srinivas Rao, P. Srinath Rajesh, Nimay Chandra Giri, Sima Das and Vikas Singh Bhadoria, Statistical Assessment of Sustainable Energy for the Lowest Feasible Levelized Cost of Electricity, IEEE ICACITE 2022, July 2022.
- 23** Nimay Chandra Giri, Ramesh Chandra Mohanty, Rabindra Nath Shaw, Surendra Poonia, Mohit Bajaj and Youcef Belkhier, "Agriphotovoltaic System to Improve Land Productivity and Revenue of Farmer," IEEE GUCON 2022, August2022.
- 24** Sima Das, Nimay Chandra Giri, Olena Rubanenko, Parijat Bhowmick, Kseniia Minakova and Dmytro Danylchenko, Telemedical System for Monitoring the Psycho-Neurological State of Patients in the Process of Rehabilitation, KhPIWeek-2022, October 2022.
- 25** Santi Behera, Kishor Sasmal, Sasmita Behera, Nimay Chandra Giri, Olena Rubanenko and Mohit Bajaj, Design and Control of 11-Level Modular Multilevel Converter with Dual Purpose Inverter for Grid Connected Photovoltaic System, ESS-2022, Nove-Dec 2022.
- 26** Ms. Debashree Debadatta Behera Attended and presented a paper Simulation of Solar Operated Grass Cutting Machine Using PVSYST Software in 13th International Conference on Material Processing and Characterization (ICMPC-2022)
- 27** Ms. Debashree Debadatta Behera Attended and presented a paper on performance evaluation of the Absorbing Plate of a Hybrid Solar Dryer for Potato Dryingat the Second International Conference on Sustainable Energy, Environment and Green Technologies (ICSEEGT 2022) organised by Poornima College of Engineering, Jaipur,

Rajasthan, India from 24-25 June 2022.

- 28** Ms. Debashree Debadatta Behera Attended and presented a paper on “Sustainable Energy Business Model and Strategies for Marketing of Clean Energy Products in Rural Areas of India” at the Second International Conference on Sustainable Energy, Environment and Green Technologies (ICSEEGT 2022) organised by Poornima College of Engineering, Jaipur, Rajasthan, India from 24-25 June 2022.
- 29** Ms. Debashree Debadatta Behera Attended and presented a paper Genetic programming approach to predict the performance characteristics of WEDM taper cutting process in 13th International Conference on Material Processing and Characterization (ICMPC-2022)
- 30** Ms. Debashree Debadatta Behera Attended and presented a paper on “Architecture for Diffusion of Clean Energy Products in Rural Areas of Odisha” at the National Seminar on Sustainable Development with Women Empowerment organised by KIIT-DU and OUAT in association with India Science Congress Association from 2-3 March 2022.
- 31** Ms. Debashree Debadatta Behera Attended and presented a paper on “Framework for Diffusion of Clean Energy Products in Rural Areas of India” at the 34th World Conference on Applied Science, Engineering and Technology held at Dubai, UAE from 23-24 March 2021.
- 32** Ms. Debashree Debadatta Behera Attended and presented a paper on “Consumer’s Perception in Adoption of Clean Energy Products in Areas of South Odisha”, International Conference on Contemporary Issues in Business Management & Economics (ICCIBME-2021)
- 33** Ms. Debashree Debadatta Behera Attended and presented a paper on paper titled “Architecture for adoption of Clean Energy products in Rural Areas of India” in National seminar on sustainable development with Women Empowerment and got certificate.
- 34** Ms. Debashree Debadatta Behera Attended and presented a paper on “Use of Clean Energy for Sustainable Livelihood in Rural Areas: A Case from South Odisha” at the International Conference on Advancements in Sustainable Technology (ICAST-2021) organised by GIFT and IFERP, from 17-18 December 2021
- 35** Mr. Deepak Kumar Sahu Attended and presented a paper titles as "Stochastic Response of RC Frame and RC Box Girder Bridges using HDMR" at the international Symposium Socio-Technological Aspects of Seismic Disaster and Mitigation STASDM-2022 on 23rd and 24th June 2022 at IIT Guwahati.
- 36** Rama Prasanna Dalai, Smita Jana, Surya Narayan Sahu published a book chapter on DEMAND SIDE MANAGEMENT.
- 37** Surya Narayan Sahu, Rama Prasanna Dalai published a Conference paper on Electrical System Design for an Educational Institute using ETAP Software in International Conference on Recent Innovations in Science, Engineering and Technology,2020.

### 3.4 CEO Retreat at Sai Resorts Vishakapatnam



CEO Retreat at Sai Resorts Vishakapatnam

### 3.5 Faculty Awards

“Provost Research Award 2022” by Centurion University of Technology and Management in recognition of research publication during 2017 to 2022 under the category of "Distinguished Achiever Award/Associate Professor".



Dr. Ashish Ranjan Dash, receiving the award from Provost, CUTM, Odisha



Dr. Rajendra Kumar Khadanga receiving the award from Provost, CUTM, Odisha

### **3.6 Future Plans**

The center tries to foster an inclusive, equitable, and diverse culture of excellence and continuous strategic improvement. Further, it attempts to leverage partnerships and collaboration with other Research centers to drive research and innovation. We thrive for translating and commercializing research findings for societal impact, which would advance the university's research brand and reputation.

## ABOUT SMART INFRA RC

THE SMART INFRASTRUCTURE RESEARCH CENTER IS A DEDICATED FACILITY FOCUSED ON ADVANCING RESEARCH AND INNOVATION IN THE FIELD OF SMART INFRASTRUCTURE. IT SERVES AS A HUB FOR INTERDISCIPLINARY COLLABORATION, BRINGING TOGETHER EXPERTS FROM VARIOUS DISCIPLINES TO DEVELOP CUTTING-EDGE TECHNOLOGIES AND SOLUTIONS FOR INTELLIGENT INFRASTRUCTURE SYSTEMS. THE CENTER CONDUCTS RESEARCH IN AREAS SUCH AS SMART CITIES, SUSTAINABLE TRANSPORTATION, ENERGY-EFFICIENT BUILDINGS, AND RESILIENT INFRASTRUCTURE, AIMING TO IMPROVE THE FUNCTIONALITY, EFFICIENCY, AND SUSTAINABILITY OF URBAN ENVIRONMENTS.



**Centurion**  
**UNIVERSITY**

*Shaping Lives...*  
*Empowering Communities...*

## CORPORATE OFFICE

HIG-4 | JAYADEV VIHAR | OPPOSITE PAL  
HEIGHTS | BHUBANESWAR | KHURDA | ODISHA | INDIA | PIN - 752050

## CAMPUS

BHUBANESWAR | PARALAKHEMUNDI | RAYAGADA | BOLANGIR |  
BALASORE | CHHATRAPUR

**2023**

[www.cutm.ac.in](http://www.cutm.ac.in)